



MALFUNCTIONING OF AIR-DELIVERING SYSTEMS: EXAMPLES OF FAN DRIVEN TRANSIENT AND OSCILLATING FLOWS

Thomas CAROLUS, Bernd HOMRIGHAUSEN

*University of Siegen, Institute for Fluid- and Thermodynamics
Paul-Bonatz-Strasse 9-11, D-57076 Siegen, Germany
thomas.carolus@uni-siegen.de*

SUMMARY

The paper reports the analysis of two initially malfunctioning industrial air-delivering systems. In both cases the air-delivering fans were the drivers for the undesired performance - not because the fans per se were of poor design but the interplay with the particular system created an unforeseen transient or oscillating flow.

The first example deals with a huge silo for powdered or granular goods in the food industry. The goods are conveyed into the silo via an aerating and fluidizing air stream. During the first start up the silo collapsed. A network analysis of the air path showed that the dimensioning of the air supplying screw compressor, safety valve and exhaust air fan was inappropriate - the comparably small exhaust fan was able to create the damaging negative gauge pressure inside the silo at a certain time instance during the loading of the silo.

The second example is a large central air conditioning system for a clean room laboratory building consisting of two parallel supply and two parallel exhaust air handling units. The pressure in the supply air handling units showed intolerably high amplitude pressure oscillation in the order of 10 to 15 Hz with the consequence that the walls of the unit were moving visibly. A number of possible known mechanisms were checked: vortex-generated unsteady flow phenomena and standing wave resonance phenomena, self-excited surge of the system due to operation of the fan on its characteristic with a positive volume flow rate/static pressure rise slope, interaction of the two parallel supply and/or exhaust air handling units and flows of the two flow fan. Eventually, an alternating suction of the two flows of one of the fans was identified. This process could be derailed by placing rectifying grids in the inlet of both flows.

INTRODUCTION

Flow induced transients and vibrations in technical systems like energy plants, air-conditioning systems, hydraulic networks, etc. cause structural failure, unacceptable noise, or general malfunctioning. The paper reports the analysis of two initially malfunctioning industrial air-delivering systems. Besides the phenomena involved it illustrates how one can systematically analyze such problems.

COLLAPSE OF A SILO FOR POWDERED GOODS

System layout and description of operation

The first example deals with a huge silo for powdered or granular goods in the food industry. The powder is conveyed into the silo via an aerating and fluidizing air stream supplied by a screw compressor. A centrifugal fan exhausts the air into the free atmosphere via a filter. The fan stops after a preset time lag upon the stop of the screw compressor. A 2-way pressure relief valve is intended to avoid dangerous pressures inside the silo. During the first start up the silo collapsed.

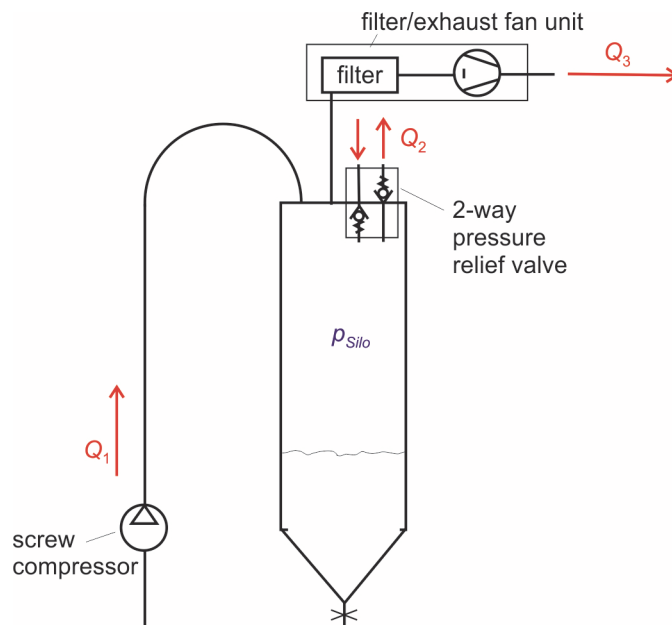

Fig. 1: Food silo with pneumatic conveying of the powdered good - red arrows indicate air path

In a subsequent measurement campaign, the pressure in the silo vs. time was recorded as in Fig. 2. Upon start, both, screw compressor and fan are set into operation. Obviously, p_{Silo} decreases continuously. The pressure relief valve opens at the preset value p_{crit} , ($p_{Silo}/p_{crit} = -1$). The pressure, however, is decreasing further as long as the exhaust fan is running. At a certain negative gauge pressure the collapse of the silo wall was observed.

Steady-state analysis of air path (network analysis)

For a first quantitative analysis it is sufficient to calculate the equilibrium state of the pressures and flow rates in the system with the powdered good not being present. Two cases are of special interest:

- regular operation with screw compressor and exhaust fan switched on

- b) operation of screw compressor is terminated but exhaust fan is still running with the corresponding volume flow rates delivered by the screw compressor:

$$Q_1 = \begin{cases} Q_{1nom} & \text{during operation} \\ 0 & \text{while operation is terminated} \end{cases} \quad (1)$$

As for most positive displacement compressors, the screw compressor's volume flow rate can be assumed to be constant, irrespective of the back pressure.

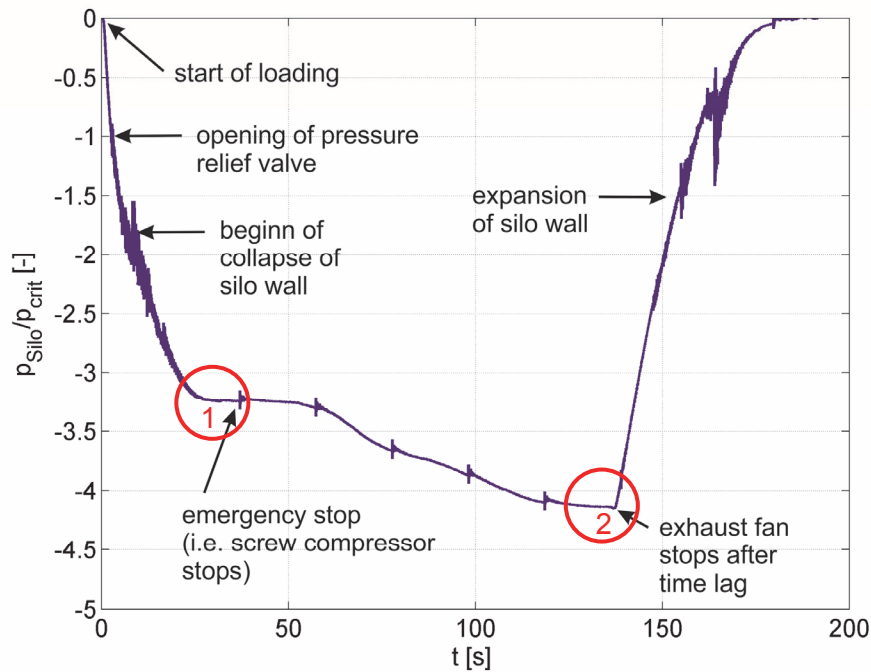

Fig. 2: Measured silo pressure vs. time upon start of loading; red circles indicate the operating points considered in the steady-state network analysis; note: the silo was already partly collapsed from previous starting up

The two-way pressure relief valve is intended to protect the silo from positive and negative gauge pressure:

$$p_{Silo} = p_{crit} + \beta Q_2 \quad (2)$$

p_{crit} is the preset opening pressure of the valve for either direction of volume flow rate Q_2 . The steepness β of the flow-depending term is determined by the design of the valve, mainly by the size of the through flow area. The complete through flow-pressure characteristic of the valve is taken from the manufacturer's documentation. Here, only the flow path of the air through the relief valve into the silo is of relevance.

p_{Silo} can also be expressed in terms of the volume flow rate Q_3 through the filter/exhaust fan unit

$$p_{Silo} = -\Delta p_{fan+filter}(Q_3) = \zeta Q_3^2 - \Delta p_{fan}(Q_3), \quad (3)$$

where ζ is a filter pressure loss coefficient (typically a quadratic function of Q_3) and $\Delta p_{fan}(Q_3)$ the pressure rise characteristic of the fan. Both are supplied by the components' manufacturers in their data sheets.

The air in the complete system is considered incompressible, which is justified because of the relatively low pressure variation in the order of some 1000 Pa. This leads to the continuity equation in the simple form

$$Q_1 + Q_2 = Q_3, \quad (4)$$

which balances all three air mass flow rates involved.

Eqs. (1) to (4) are a system of non-linear algebraic equations for Q_1 , Q_2 , Q_3 and the gauge pressure in the silo p_{Silo} . It must be solved iteratively. Negative gauge pressure in the silo means lower pressure as compared to the ambient pressure and may be the reason for denting.

Results and conclusions

The diagrams in Fig. 3 (left) show the result from the network analysis, when both, screw compressor and exhaust fan, are operating, i.e. at equilibrium operating point 1 in Fig. 2. Note that the screw compressor continuously supplies $Q_1 = Q_{1nom}$. The upper diagram represents the underlying pressure vs. through flow characteristic of the two way pressure relief valve and the operating point. Clearly, p_{Silo} falls below the preset value p_{crit} by approx. 340 %. This means that the safety valve is fully open. But it gives way only for a volume flow rate Q_2 in the order of 36 % Q_{1nom} . As consequence the filter/fan unit exhausts 136 % of Q_{1nom} and creates a suction pressure of 340 % p_{crit} , lower graph in Fig. 3. As obvious from Fig. 3 (right) the situation becomes worse when switching off the screw compressor ($Q_1 = 0 \text{ m}^3/\text{s}$) while the exhaust fan is still running (operating point 2 in Fig. 2). Here, the exhaust suction pressure is approx. 440 % p_{crit} .

As a conclusion, the dangerously low values of p_{Silo} could have only be avoided by (i) a larger pressure relief valve allowing more volume flow rate entering the silo at a given pressure differential or (ii) a less powerful exhaust fan in terms of its static pressure rise at low volume flow rates. Naively, one may not have expected these results. At first, the planner of the system suspected inadequate structural dimensions of the silo walls. Another suspicion was that the two-way pressure relief valve was failing. Only the straight-forward analysis of the complete pneumatic network (similarly to an analysis of an electric circuit, but with non-linear components) was able to reveal the reason for the malfunctioning.

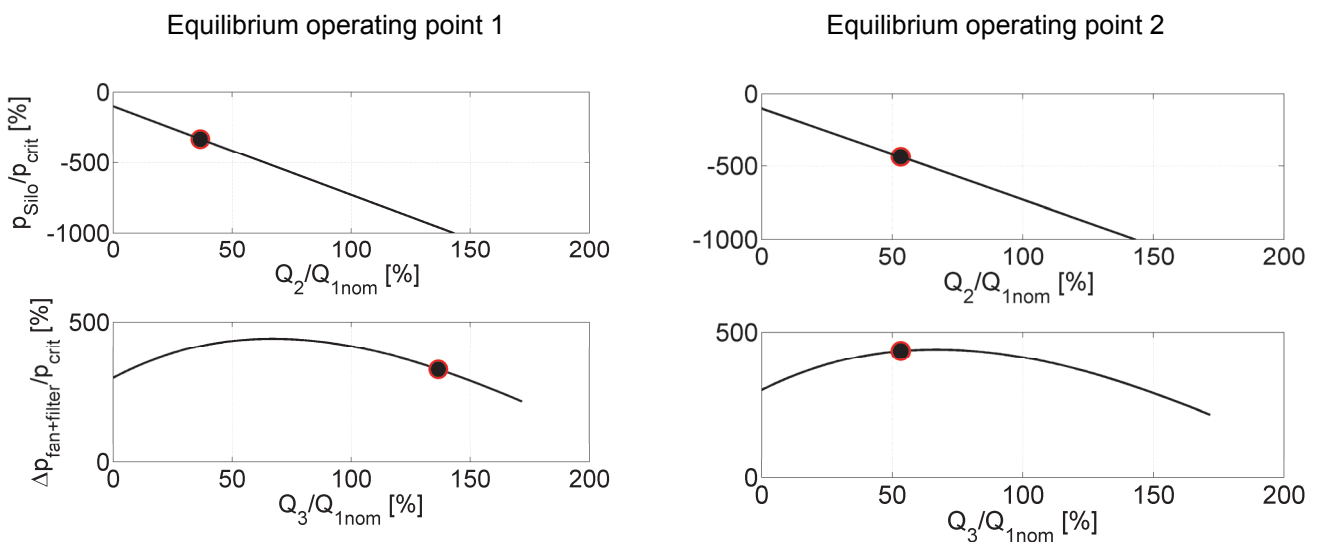

Fig. 3: Pressure in silo vs. volume flow rate through pressure relief valve (upper) and fan pressure rise vs. fan volume flow rate (lower) for equilibrium operating point 1 and 2 as in Fig. 2

PRESSURE OSCILLATIONS IN A LARGE CENTRAL AIR CONDITIONING SYSTEM

System layout and general operation

The second example is a large central air conditioning system for a clean room laboratory building. It consists of two parallel supply air handling units, which deliver air with a specified flow rate into the clean rooms, Fig. 4. The air is taken from outside of the building via a very long common concrete duct with a large cross-sectional area. Two parallel exhaust units convey the air into the free atmosphere outside of the building. The gauge pressure in the rooms is kept slightly above zero to prevent infiltration of dirt particles. The main reason for two parallel air supply units is redundancy: In case one of the units fails, the other takes over with the fan speed increased.

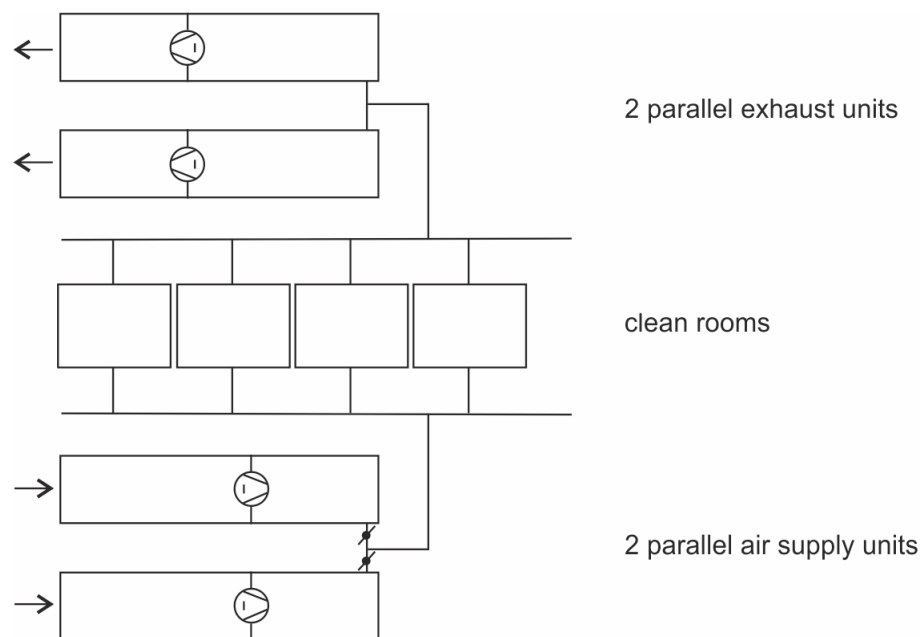

Fig. 4: Schematic layout of central air conditioning system; the volume flow controllers in the vicinity of each individual clean room are not shown

Fig. 5 shows a schematic of one supply unit. It houses the fan and a variety of air treatment components such as filters, heat exchangers, humidifiers etc. Not shown are doors between each component to the outside, allowing access for maintenance.

During commissioning intolerably high amplitude pressure oscillation in the order of 10 to 15 Hz in the supply air handling units were observed. The oscillations occurred in regular operation with the two supply units delivering air in parallel but were even more pronounced with only one supply unit operating at increased fan speed, Fig. 6. As a consequence the walls of the unit were moving visibly. No pressure fluctuations were measured in the subsequent clean rooms.

Hypotheses and indicators for possible mechanisms

Kankeko et al in their excellent book "Flow-Induced Vibrations" [1] try to classify flow-induced vibrations in general. Behn [2] gives an overview on vibrations in air-delivering technical systems and hints for prevention. Fan-related oscillations have been discussed in Bommes et al [3]. In the context of this case study the following mechanisms are candidates for the observed oscillations:

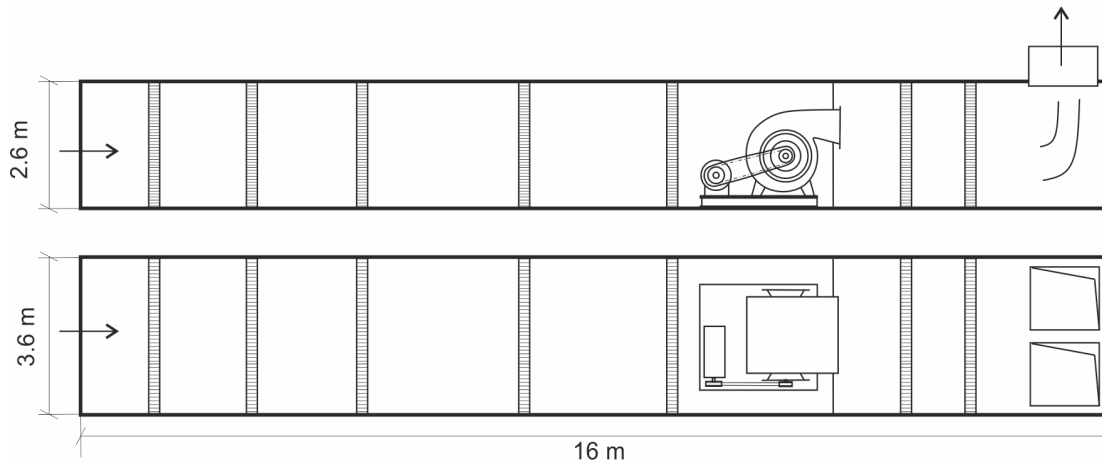

Fig. 5: Air supply unit (schematically); the hatched regions symbolize air treatment devices like a filter, humidifier etc.

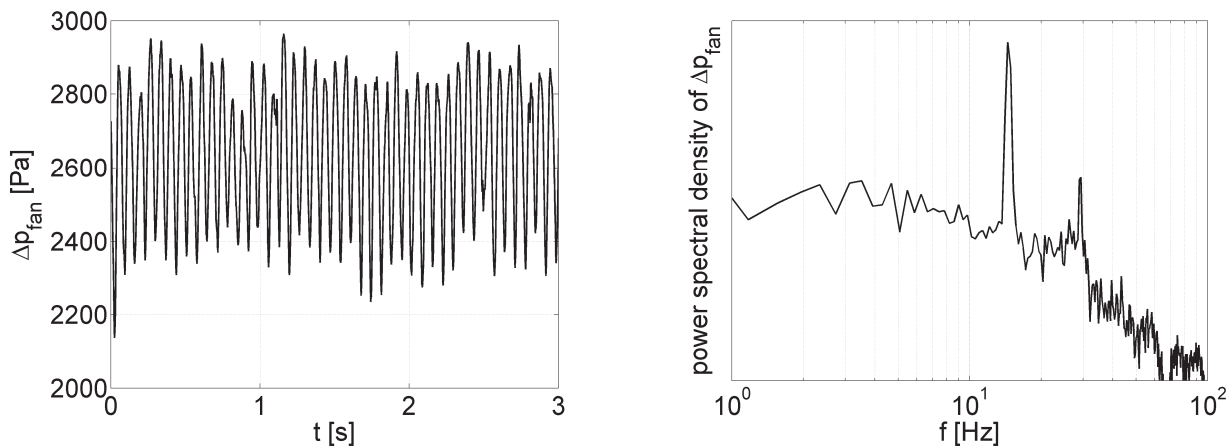

Fig. 6: Measured static fan pressure rise vs. time and spectrum, fan rotational speed $n=1230$ rpm

a) Vibration induced by cross-flow over passive elements: Vortex shedding from rigid cylinders or other elements or an ensemble of these elements subjected to external cross-flow. The vortex-shedding frequency f_{vs} , the approach flow velocity V , and the projected width normal to the flow direction d of the element are the parameters in the non-dimensional Strouhal number

$$St = \frac{f_{vs}d}{V}. \quad (5)$$

"Strouhal numbers for rectangular bodies, obtained experimentally by many researchers, seem to fit within the range $0.1 < St < 0.2$, with the exception of bodies rounded off at the corners. The Strouhal number for the latter falls within the range $0.2 < St < 0.3$." ([1], p.74). If the body is elastically supported flutter may occur. How the mechanism of vortex shedding translates into pressure fluctuations is difficult to estimate. If the vortex causing element is placed in a duct resonance can amplify the excitation to high levels. The conditions for resonance are that integer multiples of a half or quarter wavelength

$$\lambda = \frac{c_0}{f} \quad (6)$$

(depending on the boundary conditions) coincide with transverse or longitudinal dimensions of the duct. c_0 is the speed of sound.

b) Vibrations induced by internal fluid flow: When a pipe or duct and its supports are flexible, vibration may occur due to high-speed fluid flow. The vibrations can be reduced by installing supports that increase the rigidity of the pipe ([1], p. 166).

c) Vibration induced by turbomachines: Turbomachines cause flow fluctuations at their blade passing frequency and its higher harmonics

$$f_{BP} = Bn, \tag{7}$$

where B is the number of blades and n the rotational speed of the rotor. In contrast to positive displacement compressors, however, fans are weak sources of pulsations at f_{BP} .

d) If a fan is operated at part load, i.e. close to stall but not yet stalled, an instability called rotating stall may occur. As already pointed out by Gottschalk [4] in 1974, the footprint of rotating stall in a centrifugal fan impeller are pressure fluctuations with a typical frequency

$$f_{RS} \approx \frac{2}{3}n. \tag{8}$$

e) Occasionally system self-excited oscillations - sometimes called surge - of a fan system are observed. From a theoretical point of view, necessary conditions are that (i) the fan has a non-monotonic pressure rise/flow rate curve with a local maximum, (ii) its target operating point is on the left of the maximum, (iii) the system has a plenum where air can be compressed and expanded (i.e. potential energy stored), and (iv) the system has pipes where the column of air with its inertial mass can oscillate, Carolus [5]. As shown schematically in Fig. 7, the targeted operating point is dynamically unstable in a sense that - upon an infinitely small disturbance in the system - volume flow rate and pressure rise start to vary cyclically. The frequency of these self-excited oscillations has no relation with the rotating speed of the fan. It is, instead, closely related to the natural frequency of the system, in this case the frequency of an equivalent Helmholtz-resonator

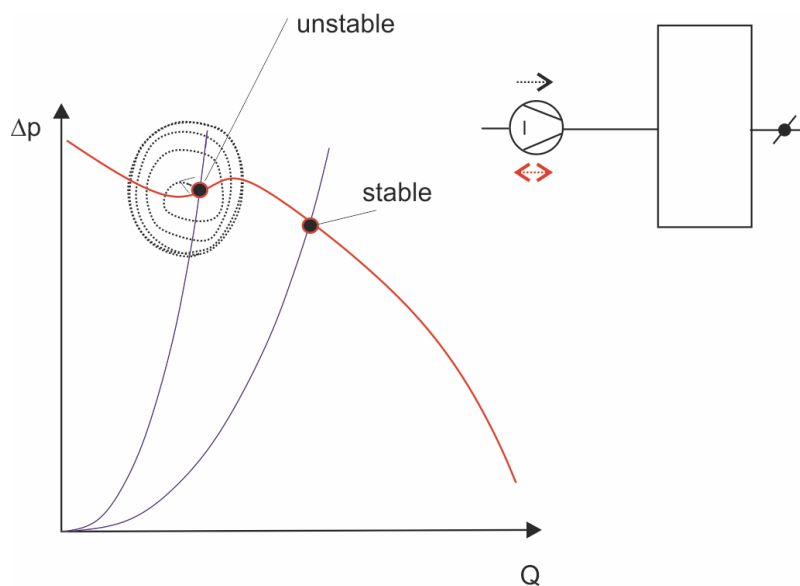

Fig. 7: Surge: In the presence of a plenum and inertial air in ducts targeted fan operating points in the area with positive slope of the characteristic are unstable

$$f_{Hh} = \frac{c_0}{2\pi} \sqrt{\frac{A}{L \cdot Vol}}, \quad (9)$$

being A and L the cross-sectional area and length of the pipe, respectively, and Vol the volume of the plenum. c_0 is the speed of sound. The inherent difficulty is the identification of the dimensions of the respective components in a system. In reality, compressibility and inertia effects exist everywhere in the system to different degrees.

f) Two fans in parallel may cause another problem, if their individual characteristics are non-monotonic and/or different. The overall resulting characteristic as seen by the system is partly ambiguous as already pointed out by Eck [6]. Each fan may switch between the three possible operating points A , B and C in the overall characteristic of Fig. 8, resulting in an unsteady increase or decrease of the volume flow rate and pressure.

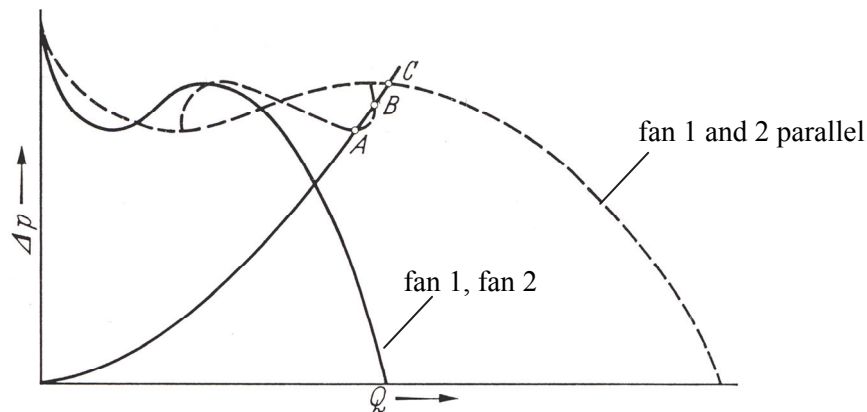

Fig. 8: Two equal fans with non-monotonic characteristic in parallel; the overall characteristic of the combined fans has an ambiguous area which may lead to unpredictable operation of both fans. From Eck [6], p. 381

Measurement campaign, analysis and conclusions

To discriminate between the various hypothetical mechanisms a purely experimental test plan was set up and measurements were carried out accordingly. Instability phenomena inherent to the complete system or the two air supply units in parallel were ruled out, because (i) the oscillations were not measurable in the clean rooms and (ii) the oscillations occurred, irrespective of one or two supply units operating. Earlier investigators proposed an interaction of the flow with the structure of the supply unit. Stiffening of components, however, did not reduce the oscillations at all. Hence, the focus was on one supply unit while the other was switched off.

Pressure readings were taken at the positions as indicated in Fig. 9. Δp_1 is the fan inlet, Δp_3 the outlet gauge pressure. Hence, $\Delta p_3 - \Delta p_1$ equals the fan's total-to-static pressure rise Δp_{fan} . The volume flow rate is determined from the pressure differential at the fan's 'calibrated' inlet nozzles. In the initial original set up the pressure tap of both inflow nozzles were connected and Δp_2 was measured. In a subsequent experiment the pressures were measured at both flows of the fan separately, i.e. Δp_{2a} and Δp_{2b} . This turned out to be crucial for detecting the driving mechanism for the oscillations. The adjustable fan rotational speed was taken from the data acquisition system in the control unit.

From the volume flow rate and cross-sectional area of the unit the average flow velocity in the unit was obtained as 2 m/s. If the observed 15 Hz oscillations originated from vortex shedding, elements with a projected width normal to the flow direction d between 15 and 42 mm were the sources. Most likely numerous air treatment devices in the supply unit have dimensions in this order of mag-

nitide. It was felt, however, that the rather low flow velocity of 2 m/s, leading to a low value of the characteristic Reynolds number, did not produce the vortex shedding responsible for the pronounced and strong oscillations with one distinct frequency. Moreover, the wavelength, associated with the frequency of the oscillations, did not suggest any standing wave resonance phenomenon.

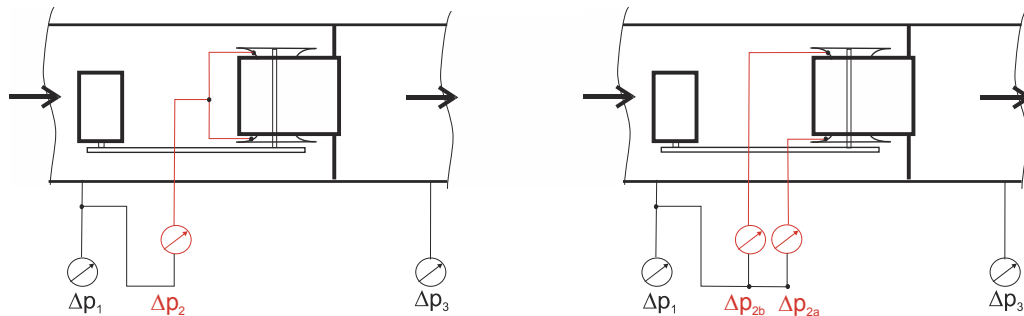

Fig. 9: Positions of pressure taps; Δp_1 is the inlet, Δp_3 the outlet gauge; Δp_2 and $\Delta p_{2a/b}$ are differential pressures for volume flow rate measurements; left: original set up with combined fan inlet nozzle pressure tap, right: temporarily separated pressure taps for each flow

Surveying the system manufacturer's design documents revealed that the fan operating point chosen was on the branch of the fan's catalogue characteristic with positive slope, Fig. 10. In a next step it was tried to measure in-situ the actual fan characteristic at a constant fan speed. This was achieved by partly blocking filter grids in the supply unit and opening maintenance doors of the supply unit. Fig. 10 depicts these in-situ data and their comparison with catalogue data. It is important to note that the volume flow rate was obtained from the time averaged Δp_2 as in the left Fig. 9. The in-situ data did not confirm fully that the effective characteristic is non-monotonic. (Nor did they match the catalogue data; the deviation may be caused by installation effects, e.g. the distance from both fan inlets to the adjacent walls of the supply unit was smaller as recommended e.g. by the standard BS EN ISO 5801-2007 [7], Fig. 11. And one of the flows was partly blocked by the belt drive.)

The shape of the in-situ characteristic and a comparison of the oscillation frequency with a coarse estimate of the Helmholtz frequency of the system ruled out the Helmholtz-type instability phenomenon.

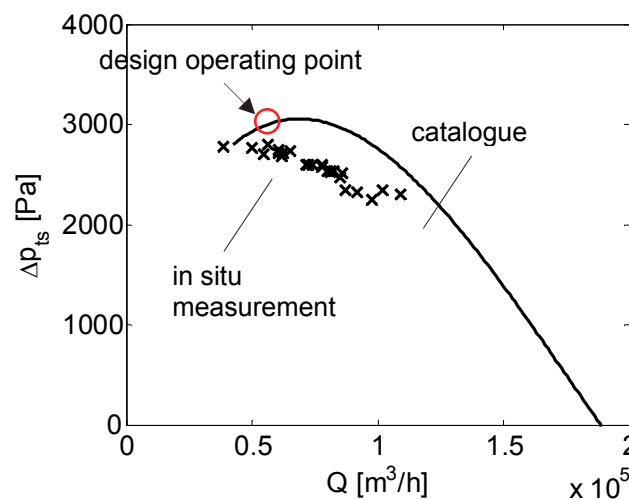

Fig. 10: Fan characteristic, catalogue vs. in-situ measured data, $n = 1197$ rpm

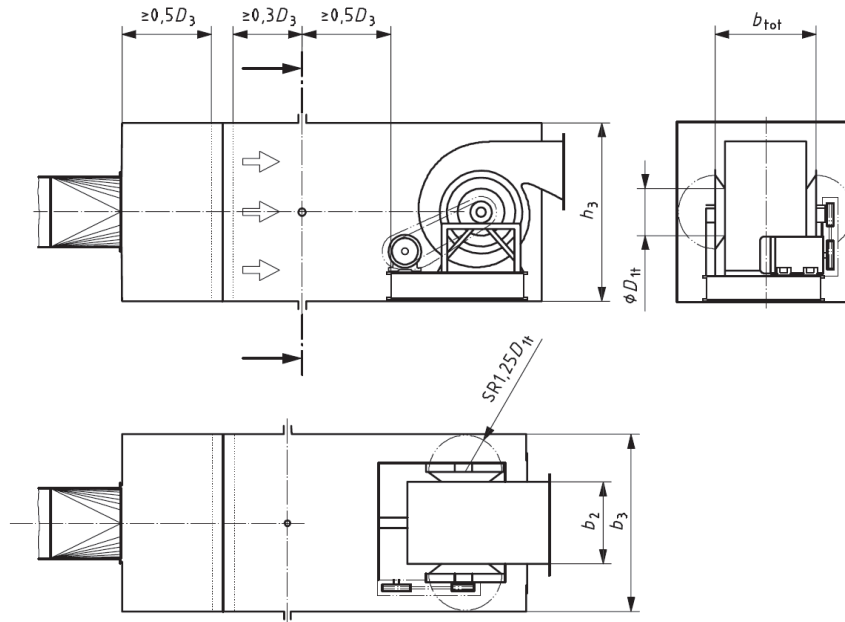

Fig. 11: Conditions for measurements of a fan characteristic according to BS EN ISO 5801-2007[7]; in this paper D_{1t} is of relevance, since in the system investigated the distance of the fan inlets did not fully comply with $SR1.25D_{1t}$

The frequency of the oscillations was found to be strongly linked to the fan rotational speed (approx. 70 % n). This was a first indication that the fan itself excites the oscillations, not due to its blade-passing frequency fluctuations but potentially due to a rotating stall phenomenon. This hypothesis was supported by the fact that the fan operating point chosen by the system designer is unluckily far left, i.e. the fan operates at part load as shown in Fig. 10.

Eventually, the measurement of the pressure differentials at the fan's inlet nozzles Δp_{2a} and Δp_{2b} revealed that *each* flow of the fan experiences oscillations with a remarkably large amplitude, phase shifted by nearly 180 degrees, Fig. 12. The former combination of both pressure taps resulting in one single signal Δp_2 tended to blur this phenomenon.

In a final experiment rectifying grids were placed in the inlet of both flows. The alternating suction nearly disappeared and the system oscillations were reduced substantially or completely eliminated.

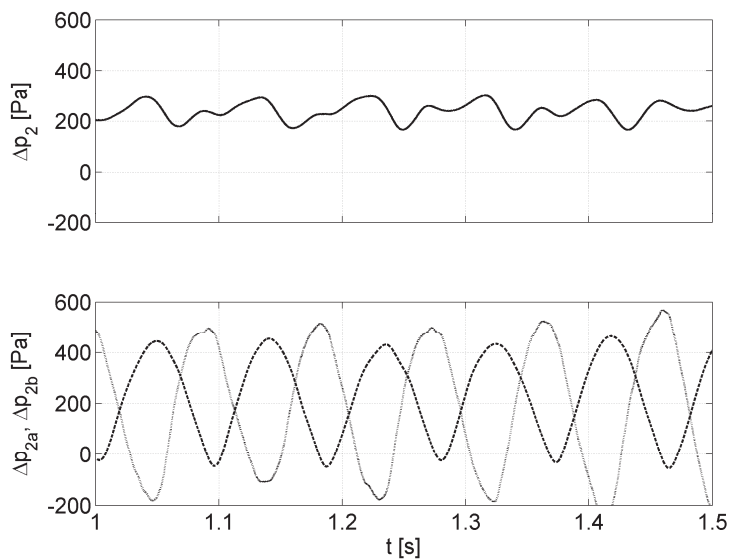

Fig. 12: Volume flow rate signals: Upper: combined fan inlet nozzle pressure taps, lower: separated pressure taps for each flow

As a conclusion the self-excited alternating suction of the two flows in parallel is the source of the system's oscillations. The alternating suction is probably caused by a combination of two phenomena: (i) rotating stall since the fan is operated far left in the unfavourable region of its characteristic and the frequency of the oscillations is always 70 % of rotor speed, (ii) an inherent instability of the two flows of the fan in parallel resulting in an ambiguity of the overall characteristic as described by Eck.

FINAL REMARKS

The paper reported the analysis of two industrial air-delivering systems which experienced structural failure or unacceptable pressure fluctuations. Once such a problem arises, customers require that it is solved within a short time. This requires a systematic approach. In some cases a model can be set up easily which allows analyzing the unexpected behavior of the system in a rational way. (Of course, the utilization of such a model in the initial planning phase may have helped to avoid the problem from the very beginning.) In this paper the first case was resolved thanks to a simple steady-state network analysis. Flow induced vibrations are more demanding. A number of phenomena are known with their own characteristic frequencies and - sometimes - amplitudes of pressure and mass or volume flow rates. Setting up a full mathematical model is often prohibitive. Therefore, systematic experiments play a key role in identifying the most relevant phenomenon.

In both case studies reported here the air-delivering fan was the driver for the undesired performance - not because the fans per se were of poor design but the interaction with the particular system created an unforeseen transient or oscillating flow.

BIBLIOGRAPHY

- [1] Kaneko, S., Nakamura, T., Inada, F., Kato, M., Ishihara, K., Nishihara, T., Mureithi, N., Langthem, M. (editors): Flow-Induced Vibrations - Classifications and Lessons from Practical Experience, Elsevier, 2. Ed., **2014**
- [2] Behn, K.: Aerodynamische Schwingungen - Schwingungen und Pumperscheinungen in lufttechnischen Anlagen. Company documentation, Reitz Ventilatoren, Höxter, Germany, **2004**
- [3] Bommers, L., Fricke, J., Grundmann, R. (editors): Ventilatoren. 2nd edition, Vulkan-Verlag Essen, **2003**
- [4] Gottschalk, M.: Untersuchung der Kennlinienstetigkeit von Radialventilatoren. Strömungsmechanik und Strömungsmaschinen - Mitteilungen des Instituts für Strömungslehre und Strömungsmaschinen, Universität (TH) Karlsruhe, Heft 17, Sept. **1974**
- [5] Carolus, T.: Theoretische und experimentelle Untersuchung des Pumpens von lufttechnischen Anlagen mit Radialventilatoren. Strömungsmechanik und Strömungsmaschinen - Mitteilungen des Instituts für Strömungslehre und Strömungsmaschinen, Universität (TH) Karlsruhe, Heft 34, Sept. **1984**
- [6] Eck, B.: Ventilatoren. 5th edition, Springer-Verlag, **1991**
- [7] BS ISO 5801:2007 Industrial fans - Performance testing using standardized airways. 2nd edition **2007-12-15**